

ALI Elite

■ **Operator's Manual**

LINE INTERACTIVE UPS
FROM ALPHA TECHNOLOGIES

- ***Tower Models:***
600A, 800A, 1000A, 1500A, 2000A,
(2500A, 3000A-CE Only)

- ***Extended Run-Time Models:***
1000XL, 1500XL, 2000XL, 3000XL

- ***Rack-Mount Models:***
800A-RM, 1250A-RM, 1500A-RM,
2000A-RM

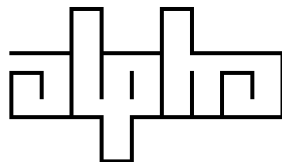

ALI Elite

■ Operator's Manual

- ***Tower Models:***
***600A, 800A, 1000A, 1500A, 2000A,
2500A, 3000A***

- ***Extended Run-Time Models:***
1000XL, 1500XL, 2000XL, 3000XL

- ***Rack-Mount Models:***
***800A-RM, 1250A-RM, 1500A-RM,
2000A-RM***

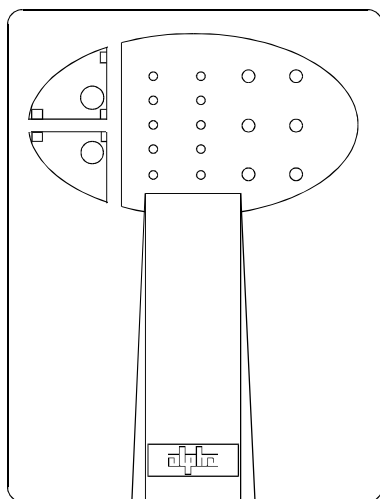

IMPORTANT SAFETY INSTRUCTIONS CONTAINED IN THIS MANUAL



CAUTION:

To reduce the risk of electrical shock and to ensure safe operation of the ALI-PLUS UPS, the following symbols are placed throughout this manual. When they appear, servicing should be performed only by qualified personnel.



A DANGEROUS VOLTAGE exists in this area. Use extreme caution.



ATTENTION: important operating instructions. Follow them closely.

SAVE THESE INSTRUCTIONS

This manual contains important installation and operating instructions. Keep it in a safe place.

NOTICE

The ALI-PLUS generates, uses and radiates radio frequency energy if not installed and used following the instructions in this manual. It complies with the limits established for a Class A computer device pursuant to Part 15 of FCC rules and the radio interference regulations of DOC. These rules are intended to provide reasonable protection against such interference when this type of equipment is used in a commercial environment.

If it appears to cause interference to radio or television reception, confirm it is present when it is turned ON and absent when it is OFF. Interference can be reduced or controlled by relocating the equipment or using an electrical circuit other than the one used by the ALI-PLUS.

IMPORTANT SAFETY PRECAUTIONS

The ALI-PLUS should be serviced by qualified personnel only.



DANGER: The units contain sealed lead-acid batteries with high energy and chemical hazards. Read this manual for safe battery handling, maintenance and disposal instructions which should only be carried out by qualified personal.

ALI-PLUS SAFETY CHECKLIST

- Carefully unpack the ALI-PLUS and report any shipping damage **at once**.
- Read this manual.** If there are any questions about safe installation or operation contact Alpha Technologies.
- For optimum performance and battery life, charge the batteries once every three months when they are not in use.
- Install the ALI-PLUS in a well ventilated area free of dust and moisture.
- Before installation compare the voltage and current requirements of the equipment to be protected to the ALI-PLUS's output. Do the same for the line voltage and current to the ALI-PLUS's input requirements.
- The ALI-PLUS should be installed on a dedicated circuit equipped with a 15 Amp. circuit breaker.
- Notify emergency personnel an Uninterruptible Power Supply (UPS) is in the building by placing a warning label on the electrical panel.
- When connecting a load, make sure it **will not** draw more current or voltage than the ALI-PLUS provides.
- The ALI-PLUS has more than one live circuit. AC power may be present at the outputs even if there is no power at the input.
- First turn on and test the ALI-PLUS, **then** connect the load(s) and the computer (if used).

IMPORTANT SAFETY PRECAUTIONS (Continued)

BATTERY HANDLING SAFETY CHECKLIST

- There are dangerous voltages inside the ALI-PLUS.*** There are no user serviceable parts inside. Battery installation and changing should be done only by trained personnel.
- Do not*** let live wires touch the ALI-PLUS's chassis. Shorted battery wires may cause a fire or explosion.
- Inspect the batteries once a year for cracks, leaks and swelling. If a battery or batteries is damaged, replace the entire string.
- Always replace batteries with those of identical type and rating. Never install old or untested batteries.
- Use insulated tools when handling batteries or working inside the ALI-PLUS.
- Remove all rings, watches, jewelry and conductive items before servicing batteries or working inside the ALI-PLUS.
- Dispose of batteries according to local regulations. Recycling is the best method.

KEEP THESE INSTRUCTIONS

TABLE OF CONTENTS

1. INTRODUCTION	1
1.1 The ALI-PLUS Advantage	2
1.2 Unpacking and Inspection Checklist	3
1.3 A Tour Of The ALI-PLUS	4
1.3.1 Front Panel Buttons and LED Indicators	4
1.3.2 Rear Panel Connectors	6
1.3.3 Tower Models (600A/800A/1000A/1500A/2000A/3000A)	7
1.3.4 XL Models (1000A/1500A/2000A/3000A)	9
1.3.5 Rack Mount Models (800A/1250A/1500A/2000A)	11
1.3.6 Output Connectors	12
2. INSTALLATION	13
2.1 Pre-Installation Checklist	14
2.2 Wiring	15
3. OPERATION	16
3.1 Operation	17
3.2 Alarms	19
3.3 Computer Interface Port	20
3.4 Monitoring Software	21
4. MAINTENANCE	22
4.1 Maintenance Tips	23
4.2 Storage	23
4.3 Internal Battery Replacement	24
4.4 External Battery Packs (XL Models Only)	25
4.5 Troubleshooting	27
4.6 Specifications	28
Warranty	36

IMPORTANT

Emergency shutdown procedure on inside back cover

Section One

Introduction

This section introduces the ALI-PLUS Uninterruptible Power Supply (UPS):

- **The ALI-PLUS advantage (Section 1.1)**
- **An unpacking checklist (Section 1.2)**
- **A description of its various panels, connections and switches (Section 1.3)**

1.1 The ALI-PLUS Advantage

- ◆ **Advanced Power Protection Technology**
The ALI-PLUS Uninterruptible Power Supply (UPS) provides continuous AC power to critical customer equipment.
- ◆ **Boost and Buck modes**
The ALI-PLUS's voltage regulation automatically raises or lowers the line voltage without using its internal batteries when it is out of specification to ensure important equipment runs smoothly.
- ◆ **RS-232 Communication**
The ALI-PLUS can be remotely monitored and controlled.
- ◆ **Rack Mount Installation**
The ALI-PLUS comes in 19-inch rackmountable models.
- ◆ **External Battery Packs**
On the XL models, extra backup time is provided by using external battery packs. They can be daisy chained together for even more backup time.
- ◆ **Overload Protection**
The ALI-PLUS automatically shuts down when it detects an overload.
- ◆ **Automatic Battery Charging**
The ALI-PLUS automatically charges the batteries even when it is turned off.

1.2 Unpacking and Inspection Checklist

PURPOSE: *Describes the unpacking procedure.*

Carefully remove the ALI-PLUS from its shipping container. Inspect the contents and make sure the following items are included:

- One ALI-PLUS with pre-installed batteries.
- One operator's manual.
- Power Cord
- CD ROM
- RS-232 Interface Cable
- Any other ordered options.



If anything is damaged or missing, contact Alpha Technologies and the shipping company **at once**. Most shipping companies have only a short claim period.

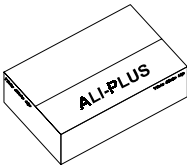

Save the Original Shipping Container

To return the ALI-PLUS, pack it in its original shipping container. If it isn't available, surround it with at least three inches of shock-absorbing material, but do not use popcorn-type packing. Alpha Technologies is not responsible for any damage caused by improper packaging of returned units.

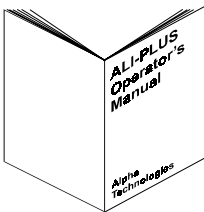

Read the Operator's Manual

Before installation or use, become familiar with your ALI-PLUS by reviewing the drawings and procedures in this manual. If you have any questions about safe installation, operation or maintenance, contact Alpha Technologies.

1.3 A Tour of the ALI-PLUS

PURPOSE: Describes the items on the ALI-PLUS's front and rear panels (Figure 1.1 to 1.15).

1.3.1 Front Panel Buttons and LED Indicators (Figures 1.1, 1.2).



Overload Indicator

This red LED turns on when loads connected to the ALI-PLUS exceeds its output capacity. Also see Section 3.2.



Back Up Indicator

This green LED turns on when the ALI-PLUS supplies battery power to the loads.



Replace Battery Indicator

This red LED turns on when the battery is discharged and must be replaced. Also see Section 4.3.



NOTE: When replacing the battery, disconnect line power then open the case. Notice the old battery's polarity before installing the new battery.



Buck AVR Indicator

This yellow LED turns on when the ALI-PLUS reduces high line voltage.



Line Normal Indicator

This green LED turns on when the line voltage is normal.



Boost AVR Indicator

This yellow LED turns on when the ALI-PLUS raises low line voltage.



Load bar graph

This display shows the power being drawn by the load(s).



Power bar graph (Battery Charge/Line Voltage)

This shows the current battery charge as a percentage of battery capacity. It also displays the line voltage.

1.3 A Tour of the ALI-PLUS (Continued)

OFF button

This button turns off the ALI-PLUS and the power to the load(s)
(Also see Section 3.1)

On/Test Button

When the ALI-PLUS is plugged in, pressing this button turns it on and it begins to power the loads. It also starts the self-test and turns on the line voltage display (Also see Section 3.1).

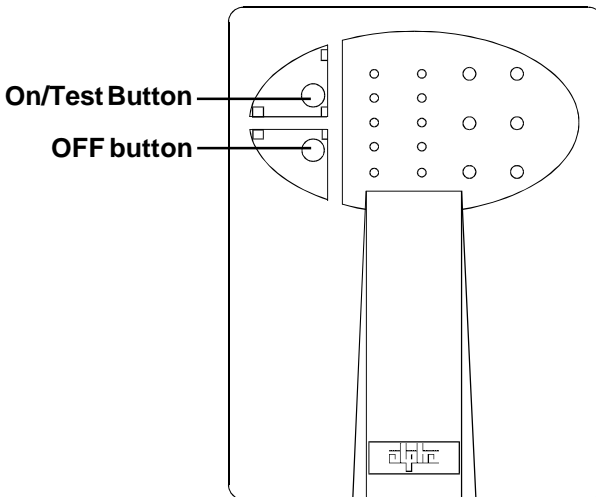

Figure 1.1
ALI-PLUS Tower Model Front Panel

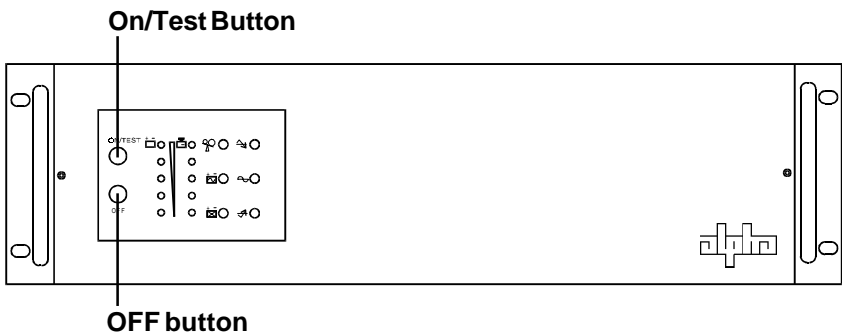

Figure 1.2
ALI-PLUS Rackmount Front Panel

1.3 A Tour of the ALI-PLUS (Continued)

1.3.2 REAR PANEL CONNECTORS

Common to all models:

- **OUTPUT POWER RECEPTACLES**
- **INPUT POWER RECEPTACLE**
- **TELEPHONE/MODEM SURGE PROTECTION**
Provides surge protection for telephone and modem lines for connection to the Internet.
- **COMPUTER INTERFACE**
Provides RS-232 and relay signals to support NOVELL, UNIX, DOS, WINDOWS 3.1X/95/98/NT and other operating systems.

Factory Installed Option:

- **SNMP INTERFACE PORT**
Provides SNMP adapters for 10-BaseT Ethernet and Token Ring connectors. Using the RS-232 communication port, this adapter provides real-time information to the network manager.
Caution: Use only supplier-approved SNMP monitoring cables.

120 V Models Only:

- **SITE WIRING FAULT INDICATORS**
It turns ON when the ALI-PLUS is connected to an improperly wired AC power outlet (Section 2.2).

XL Models Only:

- **EXTERNAL BATTERY PACK CONNECTOR (Optional)**
Caution: Use only supplier-approved cables.

On Selected Models:

- **INPUT CIRCUIT BREAKER**
It opens when the power drawn by the loads exceeds the input receptacle's capacity. The circuit breaker's center plunger is extended when tripped

1.3 A Tour of the ALI-PLUS (Continued)

1.3.3 Tower Models: 600A, 800A, 1000A, 1500A, 2000A, 2500A, 3000A (Figures 1.3 to 1.8).

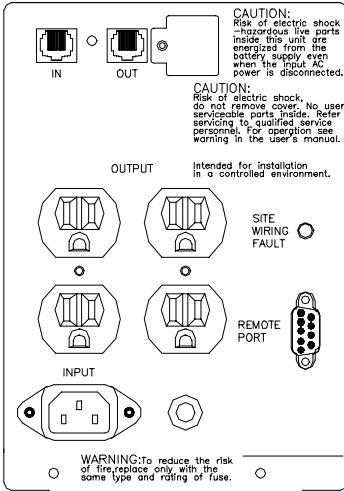

Figure 1.3

Rear Panel of Models
600A/800A/1000A (120V)

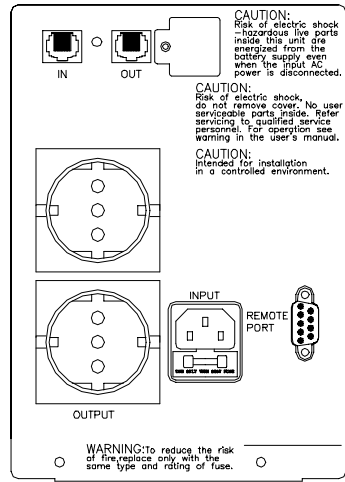

Figure 1.4

Rear Panel of Models
600A/800A/1000A (230V)
Europe

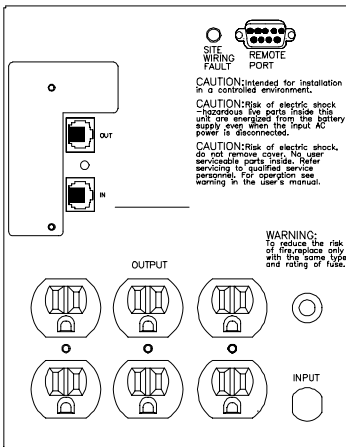

Figure 1.5

Rear Panel of Models
1500A/2000A (120V)

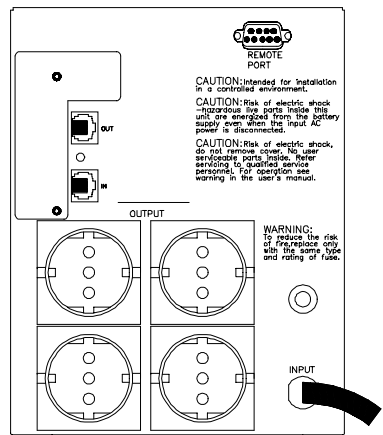

Figure 1.6

Rear Panel of Models
1500A/2000A (230V) Europe

1.3 A Tour of the ALI-PLUS (Continued)

1.3.3 Tower Models (Continued)

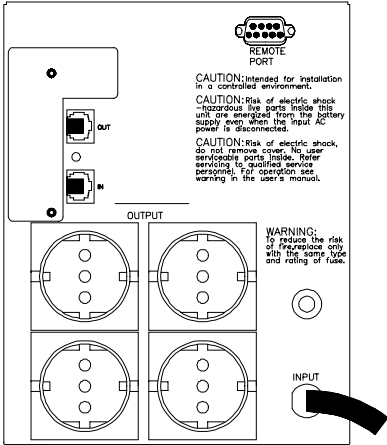

Figure 1.7
Rear Panel of Model 2500A
(230V) Europe

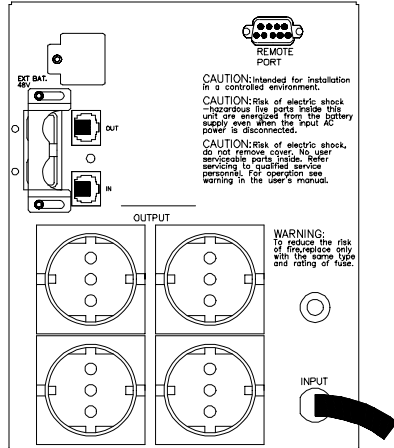

Figure 1.8
Rear Panel of Model 3000A
(230V) Europe

1.3 A Tour of the ALI-PLUS (Continued)

1.3.4 XL Models (Figures 1.9 to 1.15)

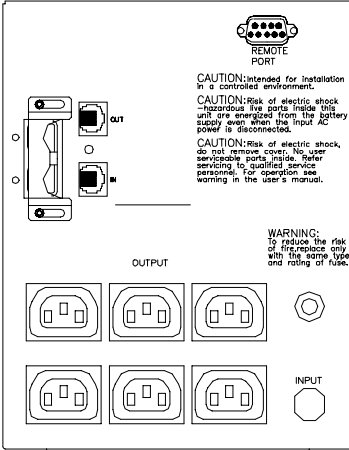

Figure 1.9

Rear Panel of Model 1000 XL (230V) IEC

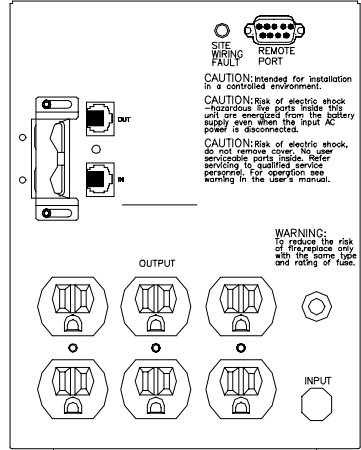

Figure 1.10

Rear Panel of Model 1000 XL (120V) IEC

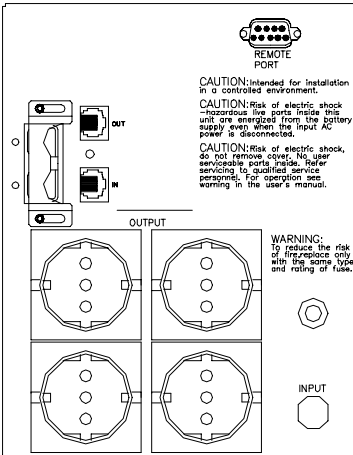

Figure 1.11

Rear Panel of Model 1000 XL (230V) Europe

1.3 A Tour of the ALI-PLUS (Continued)

1.3.4 XL Models (Continued)

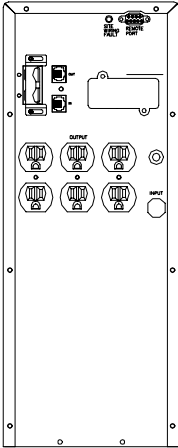

Figure 1.12
Rear Panel of Model
1500XL-2000XL (120V)

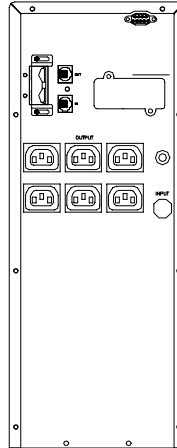

Figure 1.13
Rear Panel of Model 1500XL-
3000XL (230V) IEC

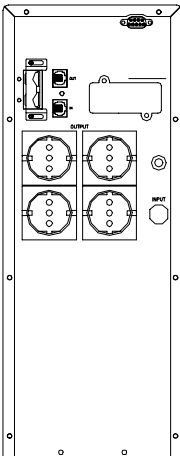

Figure 1.14
Rear Panel of Model 1500XL-
3000XL (230V) Europe

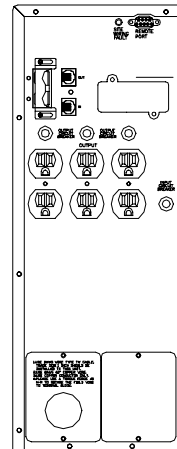

Figure 1.15
Rear Panel of Model 3000XL
(120V)

1.3 A Tour of the ALI-PLUS (Continued)

1.3.5 Rackmount Models: 800A-RM, 1250A-RM, 1500A-RM, 2000A-RM (Figures 1.16 to 1.19)

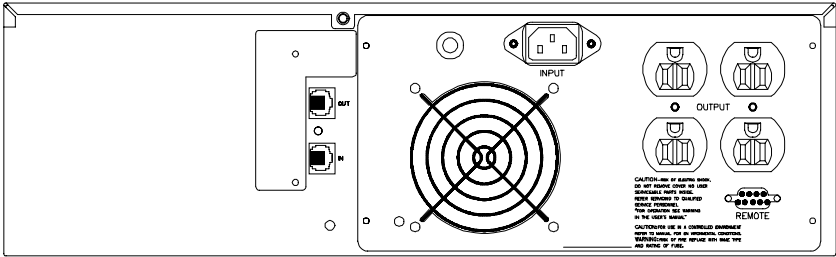

Figure 1.16
Rear Panel of Models 800A-RM, 1250A-RM (120V)

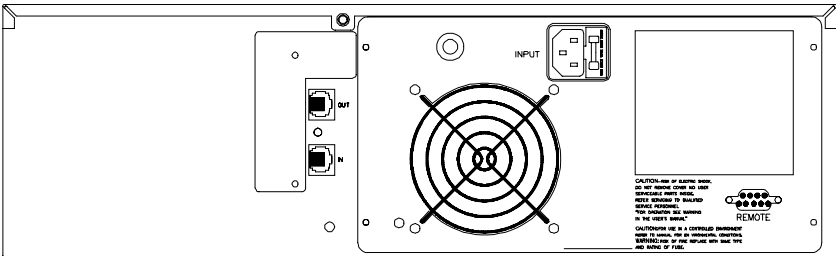

Figure 1.17
Rear Panel of Models 800A-RM, 1250A-RM (230V)
(For the available output connectors see Figure 1.20)

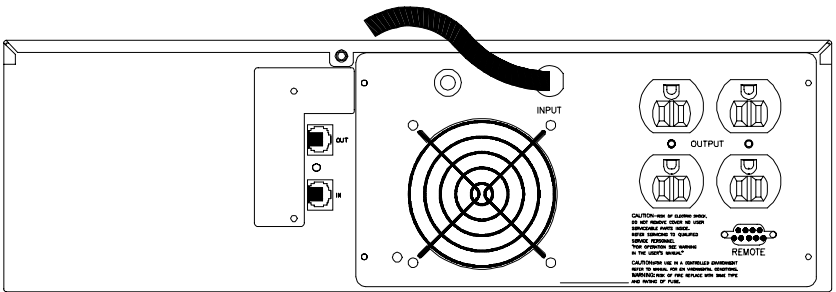

Figure 1.18
Rear Panel of Models 1500A-RM, 2000A-RM (120V)

1.3 A Tour of the ALI-PLUS (Continued)

1.3.5 Rackmount Models (Continued)

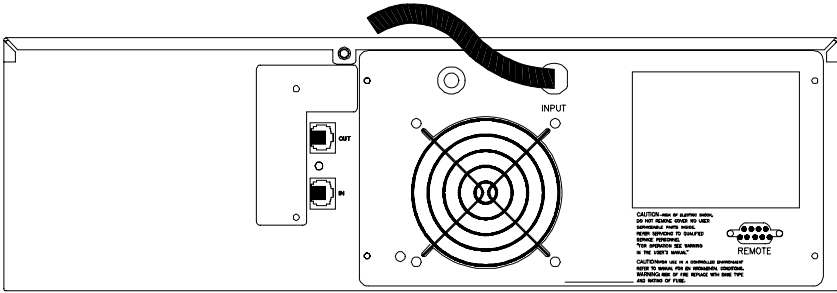

Figure 1.19

Rear Panel of Models 1500A-RM, 2000A-RM (230V)
 (For the available output connectors see Figure 1.20)

1.3.6 Output Connectors

Multiple configurations of output connectors are available at the factory for various requirements. Models shown with blank output plates can have any of the connectors shown below installed

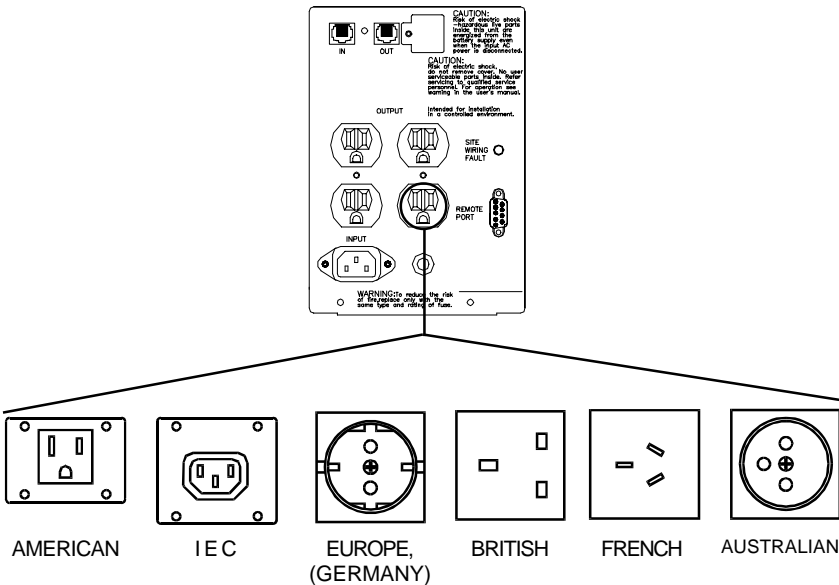

Figure 1.20

Available ALI-PLUS Output Connectors

Section Two

Installation

This section describes how to install and connect the ALI-PLUS:

- **A pre-installation checklist (Section 2.1)**
- **How to connect it (Section 2.2)**

2.1 Pre-Installation Checklist

PURPOSE: Provides a pre-installation checklist for the ALI-PLUS.

Placement
Install the ALI-PLUS in a dust-free, well ventilated area. Do not operate it where the temperature and humidity exceeds the limits listed in the specifications.

Connect the Computer Interface (If Used)
RUPS series software (or other power management software) and interface kits can be used with the ALI-PLUS. Use only manufacturer-approved kits or cables.

If used, connect the cable to the 9-pin port on the back panel.

Connect the External Battery Pack (If Used)
Before connection, confirm that the external battery pack and the connector cable is compatible with the ALI-PLUS.

Note: Use only manufacturer-approved external battery connection cables.

Connect the Telephone/Modem Lines (If Used)

 **Danger:** The Telephone/Modem surge protector is for indoor use *only*. Never install telephone wiring during a lightning storm.

Connect a single line telephone or a modem line into the telephone/modem input socket on the rear panel. The RJ-45/RJ-11 modular sockets accepts standard single line telephone connections.

Note: The current limiting feature could become inoperable if improperly installed. The wall telephone line is plugged into the "IN" connector, and the protected device (telephone, modem, etc.) is plugged into the "OUT" connector.

2.2 Wiring

PURPOSE: Describes how to wire the ALI-PLUS.

1 Connect to Line Power

Connect line power to the input power connector.

2 Check the Site Wiring Fault Indicator

After plugging in the ALI-PLUS, check the site wiring fault indicator on the rear panel (Section 1.3.2). It lights if the UPS is plugged into an improperly wired AC power outlet. Wiring faults include ground-hot-neutral polarity reversal and an overloaded neutral circuit.

TIP: The indicator is advising you to have the wiring checked by a qualified professional.

3 Charge the Battery

The battery is charged whenever the ALI-PLUS is connected to utility line power. For best results, charge the battery for 4 hours before first use.

4 Connect the Loads



Caution: Never connect a laser printer or plotter to the ALI-PLUS. They may overload it.

Plug the loads into the output connectors on the ALI-PLUS's rear panel. To use the ALI-PLUS as a master on/off switch, switch ON all the loads.

Section Three

Operation

This section describes how to operate the ALI-PLUS:

- **Its operating modes (Section 3.1)**
- **Its alarms (Section 3.2)**
- **The communications port (Section 3.3)**
- **Remote monitoring software (Section 3.4)**

3.1 Operation

PURPOSE: Describes the ALI-PLUS's operating modes.

Switch On	<p>To turn the unit on, plug it into the line power outlet. Then press the ON/TEST button for more than 1 second. The ON LINE LED turns ON and it performs a self-test each time it is switched on.</p> <p>Note: When switched off, it continues to charge the battery and responds to commands sent via the computer interface port.</p>
Switch Off	<p>Press the OFF button until all LEDs are OFF.</p>
Self-Test	<p>This verifies the unit's proper operation and the battery's condition. When it is in on-line mode, pushing the ON/TEST button for more than 1 second starts the self test. During the test it operates in back up mode with battery power supplied to the loads. The On-Battery LED is on during the test.</p> <p>If it passes the self-test, the unit returns to on-line operation with the On-Line LED turned on and the On-Battery LED turned off.</p> <p>If it fails the self-test, the unit returns to on-line operation and turns on the Replace Battery LED without affecting the load(s). Recharge the battery overnight and repeat the self-test. If the Replace-Battery LED is still on, ask your Alpha dealer to replace the battery.</p>
Mute Buzzer	<p>In "BACK UP" mode, push ON/TEST button for more than 1 second to shut off the audible alarm (This cannot be done during LOW BATTERY or OVER-LOAD modes).</p> <p>Note: In Back-Up mode, the unit can be turned off if no loads are running.</p>

3.1 Operation (Continued)

Load bar graph	<p>The 5-LED display (Section 1.3.1, Page 4) shows the power drawn by the load(s). It indicates the percentage of the unit's rated capacity currently being used.</p> <p>For example, if three LEDs are on, the load is drawing between 50% and 67% of its capacity.</p> <p>If the unit is overloaded, the overload LED is on and the audible alarm sounds (Section 3.2).</p>
Battery charge bar graph	<p>The 5-LED display (Section 1.3.1, Page 4) shows the present battery charge as a percentage of its capacity. When all five LEDs are on, the battery is fully charged. When only two LEDs are on, it has less than two minutes of run time available.</p>
Cold start	<p>When the unit is off and there is no line power, the cold start mode provides battery power to the loads. Press the ON/TEST button until it beeps.</p>
Shutdown mode	<p>In shutdown mode the unit stops supplying power to the load and waits for the return of line power. The front panel LEDs sequentially flash.</p> <p>A remote computer connected to the unit can command a shutdown even if there is no line power. This is usually done to preserve battery capacity after the shutdown of protected equipment.</p>

3.2 Alarms

PURPOSE: Describes the ALI-PLUS's alarms.

Back Up	<p>When the <i>Back UP LED</i> is on and the audible alarm sounds, the ALI-PLUS is in back up mode. The batteries are providing power to the load(s). The alarm automatically stops when it returns to normal operation.</p> <p>TIP: Pressing the <i>ON/TEST button</i> shuts off the alarm.</p>
Low Battery	<p>When in back up mode and the batteries are almost discharged, the ALI-PLUS beeps rapidly until the batteries are discharged or line power returns</p>
Overload	<p>A continuous alarm means the ALI-PLUS is overloaded. Disconnect nonessential loads.</p>
Replace Battery	<p>When the ALI-PLUS beeps and the <i>Replace Battery LED</i> is on, the battery failed the self-test. See Section 4.3 for battery replacement instructions or call your Alpha Technologies dealer for servicing.</p>

3.3 Computer Interface Port

PURPOSE: *Describes the RS–232 communications port (Figure 3.1).*

The communication port may be connected to a computer. It provides remote monitoring of the ALI–PLUS and allows remote control in some cases.

The major functions include:

- Line power failure warning.
- Warns to close any open files before the battery is exhausted.
- Turns off the ALI–PLUS.
- SNMP Interface Port

Some computers are equipped with a connector to link it with the communication port. But it may need a special plug-in card and monitoring software. Contact your dealer for details on the various interface kits.

Communications Port Specifications (Figure 3.1):

1) Pin 5 and 2 are open collector outputs which must be pulled up to a common referenced supply no greater than +40 VDC.

The transistors are capable of a maximum non–inductive load of 25 mA DC. Use only pin 7 as the common.

2) Pin 5 generates a High to Low signal when the internal battery has less than 5 minutes of back up time left.

3) Pin 2 generates a High to Low signal during a line failure.

4) The ALI–PLUS shuts down when a high remote shutdown input is sustained on pin 6 for 0.36 seconds.

5) Pin 9 is the RS–232 data output (TxD).

6) Pin 6 is the RS–232 data input (RxD).

NOTES:

1) Open collector rating is +40V, 0.15A (non–inductive).

2) Pin 7 is connected to ground.

3.3 Computer Interface Port (Continued)

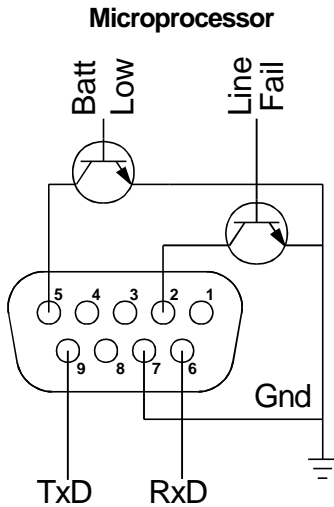

Figure 3.1
RS-232 Communications Port
Pin Diagram

3.4 Monitoring Software

PURPOSE: Describes the Interface Kit

Interface kits are available for remote monitoring. Each includes a computer cable and the software needed to connect a computer to the ALI-PLUS.

Connect the interface cable to the REMOTE PORT on the ALI-PLUS's rear panel and to either COM 1 or COM 2 on the computer. Other installation instructions are included on the READ.ME file.

Caution: Use only factory approved cables.

The RUPS series software uses RS-232 communications for remote monitoring and for an orderly shutdown during a power failure. The RUPS displays readouts such as Voltage, Frequency, Battery Level, etc..

Software is available for Windows 95/98/NT, Novell Netware and others. Call your dealer for more information.

Section Four

Maintenance

This section describes how to maintain the ALI-PLUS:

- **Maintenance Tips (Section 4.1)**
- **Storage Instructions (Section 4.2)**
- **Battery Replacement (Section 4.3)**
- **External Battery Packs (Section 4.4)**
- **Troubleshooting (Section 4.5)**
- **Specifications (Section 4.6)**

4.1 Maintenance Tips

PURPOSE: *Describes how to maintain the ALI-PLUS.*

- Keep it clean. Vacuum the air intake periodically.
- Regularly wipe the case with a soft, damp cloth.
- Every month check for loose and bad connections.
- Mount it on a level surface.
- Allow at least 10 cm of clearance between the rear panel and the wall. Keep the ventilation intake open.
- Avoid direct sunlight, rain and high humidity.
- Keep it away from open flames or heat sources.
- Do not stack anything on top of it.
- The normal operating temperature is 0–40 °C.

4.2 Storage

PURPOSE: *Describes how to store the ALI-PLUS.*

Storage conditions

Store the ALI-PLUS covered and upright in a cool, dry location. Before storage, charge the battery for at least 4 hours. Remove any accessories in the accessory slot and disconnect any cables connected to the computer interface port to avoid draining the battery.

Extended storage

During extended storage in environments where the temperature is -15 to +30 °C (+5 to +86 °F), charge the battery every 6 months.

During extended storage in environments where the temperature is +30 to +45 °C (+86 to +113 °F), charge the battery every 3 months.

4.3 Internal Battery Replacement

PURPOSE: *Describes how to replace the internal battery.*

The battery should last for 3–5 years before needing replacement.

Tools Required:

- Phillips Screwdriver



DANGER: Before starting, remove watches, rings, jewelery or other conductive materials.

Procedure:

- 1 Unplug the ALI-PLUS from line power. Disconnect all equipment.
- 2 Disconnect the AC power cord.
- 3 For the tower models, turn the unit upside down and unscrew the 4 screws holding the unit's cover to the chassis (**NOTE:** For the 1/2 KVA units, there is one screw on each side of the front of the unit that must be unscrewed).

(**NOTE:** For the rack mount models, take the top cover off.)

- 4 Holding the chassis and cover together firmly, turn the unit right side up.
- 5 Carefully slide off the cover and place it to the side.



DANGER: Do not touch any inner components when changing the battery. Do not let the battery wires touch any metallic or conductive parts of the unit

- 6 Remove the 2 connecting wires from the battery. (**NOTE:** Before removing the wires, note their polarity.)
- 7 Remove the battery from the unit
- 8 Place the new battery in the same position/direction and reconnect the wires [red wire: positive(+), black wire: negative(-)].
- 9 Reassemble the unit.
- 10 Reconnect the unit.

4.4 External Battery Packs (XL Models Only)

PURPOSE: Describes how to connect the external battery packs.

SAFETY TIPS:

- **Do not** dispose of the battery by burning it.
- **Do not** open the battery.
- Use insulated tools.
- Remove rings, watches, jewelry and other conductive items before starting this procedure.

PROCEDURE

- 1: Turn off the UPS.
- 2: Remove the cover from the UPS's back panel.

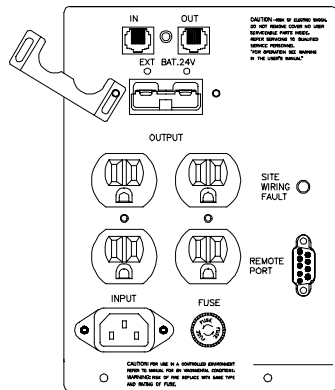

4.4 External Battery Packs (XL Models Only)

3: Connect the battery's connector to the UPS's battery connector.

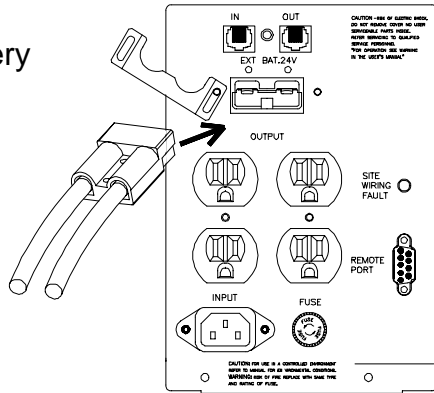

4: Turn on the UPS.
5: Turn on the loads.

PROCEDURE FINISHED

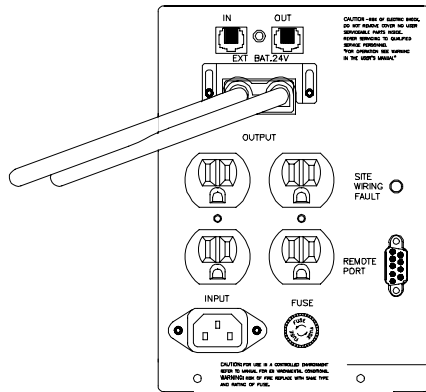

4.5 Troubleshooting

PROBLEM	CAUSE	SOLUTION
UPS does not turn on	ON/Test Button not pushed	Push the ON/Test Button
	UPS input circuit breaker tripped	Reduce the load on the UPS by disconnecting loads and reset the circuit breaker
	Low or no line voltage	See that line voltage is within specifications
UPS does not turn on or off	Computer interface or plugged in accessory faulty	Disconnect the interface or accessory. If UPS works, check removed item for faults
UPS operates in On Battery when line power is OK and available	UPS's input circuit breaker is tripped	Turn off loads until the overloading is eliminated
UPS does not provide expected backup time	The battery is weak or discharged	Charge the battery. If this doesn't work, replace the batteries.
	The UPS is overloaded	Turn off loads until the overloading is eliminated
Front panel LEDs flash sequentially	The UPS has been shut down by remote control	The UPS will automatically start when line power returns
All LEDs are flashing and the UPS emits a tone	Internal UPS fault	Turn the UPS off and call vendor for repair
The UPS operates normally but the site wiring fault indicator is lit	There is a building wiring error such as missing ground or hot to neutral wire reversal	Have a qualified electrician inspect and repair the wiring
The low battery LED is on and all other LEDs are off	The UPS is shut down and the battery is discharged	The UPS will automatically start when line power returns. The UPS will automatically start recharging the battery
The replace battery LED is on	The battery is discharged	Recharge the battery for at least 4 hours. If the problem continues, replace them.

4.6 Specifications (600A–2000A Tower Models)

MODEL		600A	800A	1000A	1500A	2000A
INPUT	Capacity	600VA	800VA	1000VA	1500VA	2000VA
	Voltage	100V, 110V, 120V, 220V, 230V, 240V +/- 25% at line input, single phase				
	Frequency	50 or 60 Hz +/- 5% (auto sensing)				
OUTPUT	Voltage (On Battery)	Pure sine wave output at nominal +/- 5%				
	Frequency (On Battery)	50 or 60 Hz +/- 0.5%				
	Voltage Regulation AVR	AVR automatically increases output voltage 15% above input voltage if line voltage is -9% to -25% of nominal. AVR automatically decreases output voltage by 15% if input voltage is +9% to +25% above nominal line voltage.				
PROTECTION AND FILTERING	SPIKE	320 Joules, 2ms				
	UNIT INPUT	Fuse or Breaker for overload and short circuit protection				
	EM/RFI Filter	10 dB at 0.15 MHz, 50 dB at 30 MHz				
	Overload Protection	Automatic shutdown if overload exceeds 110% of nominal for 20 seconds, or 125% for 2 seconds				
	Transfer	2/4 milliseconds, including detection time				
	Short Circuit	UPS output cut off immediately or input fuse or breaker protection				
BATTERIES	Type	Hot swappable, Sealed, Maintenance free gelled lead acid				
	Typical Recharge	4 hours to 90% capacity				
	Protection	Automatic self-test and over discharge protection				
	Back Up Time: At full load (Min)*	12	8	5		
	Back Up Time: At half load (Min)*	33	22	16		
	Nominal Battery Voltage	24 V			36 V	48 V
	Charger Current	1.5A to 2.5A				
	Supplied Battery Packs	Built In				

NOTE: Specifications subject to change without notice.

4.6 Specifications (600A–2000A Tower Models, Continued)

MODEL		600A	800A	1000A	1500A	2000A
PHYSICAL	Net Weight Kg(lbs)	13.8 (30.4)	14.5 (31.9)	15 (33)	25 (55)	30 (66)
	Dimensions in (mm)	5.5x17.5x7.9 (140x445x200)			6.7x17.7x8.9 (170x450x226)	
INTERFACE	RS-232	Supports both RS-232 and dry contact signal. Provides power management functions and diagnostic functions including power status, battery low, schedule UPS ON/OFF, battery/load level display. Compatible with Windows 95/98/NT, Novell and Unix.				
CONFORMANCE	Safety	UL, cUL, TUV, CE, FCC				
	Surge	Meets IEEE Standard 587				
	Warranty	Two Years				
ALARM	Battery Back-up	Slow beeping sound (0.25 Hz)				
	Battery Low	Rapid beeping sound (1.00 Hz)				
	Overload	Continual beeping sound				
ENVIRONMENT	Ambient Operation	19600 FT (6000 M) Maximum elevation, 0-95% humidity, non-condensing, 0-40 degrees C				
	Audible noise	< 40 dBA (at 1 meter)			< 45 dBA (at 1 meter)	
	Storage	49000 FT (15000 M) maximum elevation				

NOTE: Specifications subject to change without notice.

*** NOTE:** Battery backup times are approximate and will vary depending on factors such as ambient temperature, loads and battery age at the installation site.

4.6 Specifications (2500A, 3000 A Tower Models)

MODEL		2500A	3000A
INPUT	Capacity	2500VA	3000VA
	Voltage	220v, 230v, 240v +/- 25% at line input, single phase	
	Frequency	50 or 60 Hz, +/- 5% (Auto Sensing)	
OUTPUT	Voltage (On Battery)	Pure sine wave output at nominal +/- 5%, -10% after low battery warning	
	Frequency (On Battery)	50 or 60 Hz, +/- 0.5%	
	Voltage Regulation AVR	AVR automatically increases output voltage 15% above input voltage if line voltage is -9% to -25% of nominal. AVR automatically decreases output voltage by 15% if input voltage is +9% to +25% above nominal line voltage.	
PROTECTION AND FILTERING	SPIKE	320 Joules, 2mS	
	UNIT INPUT	Fuse or circuit breaker for overload and short circuit protection	
	EM/RFI Filter	10 dB at 0.15 MHz, 50 dB at 30 MHz	
	Overload Protection	Automatic shutdown if overload exceeds 110% of nominal for 20 seconds or 125% for 2 seconds	
	Transfer	2/4 milliseconds, including detection time	
	Short Circuit	Output cut off immediately or input fuse/breaker protection	
BATTERIES	Type	Hot swappable, sealed, maintenance free gelled lead acid	
	Typical Recharge	4 hours to 90% capacity	
	Protection	Automatic self test and over discharge protection	
	Back-Up Time: At Full Load*	4 Min	9 Min
	Back-Up Time: At Half Load*	13 Min	25 Min
	Nominal Battery Voltage	48 V	
	Charge Current	2A	
	Supplied Battery Packs	Built In	External Pack

4.6 Specifications (2500A, 3000 A Tower Models)

MODEL		2500A	3000A
PHYSICAL	Net Weight Kg (lb)	30 (66.1)	21 (46.3)
	Dimensions in (mm) WxDxH	6.7x17.7x8.9 (170x450x226)	
ALARM	Battery Backup	Slow beeping sound (~0.25 Hz)	
	Battery Low	Rapid beeping sound (~1.00 Hz)	
	Overload	Continuous beeping sound	
INTERFACE	RS-232	Supports both RS-232 and dry contact signal. Provides power management functions and diagnostic functions including power status, battery low, schedule UPS ON/OFF, battery/load level display. Compatible with Windows 95/98/NT, Novell and Unix.	
CONFORMANCE	Safety	CE Only	
	Surge	Meets IEEE standard 587	
ENVIRONMENT	Ambient Operation	19600 Ft (6000 M) max elevation, 0-95% humidity non-condensing, 0-40 deg C	
	Audible Noise	<40 dBA at 1 meter from surface	
	Storage	49000 Ft (15000 M) max elevation	

NOTE: Specifications subject to change without notice.

*** NOTE:** Battery backup times are approximate and will vary depending on factors such as ambient temperature, loads and battery age at the installation site.

4.6 Specifications (XL Models)

MODEL		1000XL	1500XL	2000XL	3000XL (CE Only)
INPUT	Capacity	1000VA	1500VA	2000VA	3000VA
	Voltage	100V, 110V, 120V, 220V, 230V, 240V +/- 25% at line input, single phase			
	Frequency	50 or 60 Hz, +/- 5% (Auto Sensing)			
OUTPUT	Voltage (On Battery)	Pure sine wave output at nominal +/- 5%, -10% after low battery warning			
	Frequency (On Battery)	50 or 60 Hz, +/- 0.5%			
	Voltage Regulation AVR	AVR automatically increases output voltage 15% above input voltage if line voltage is -9% to -25% of nominal. AVR automatically decreases output voltage by 15% if input voltage is +9% to +25% above nominal line voltage.			
PROTECTION AND FILTERING	SPIKE	320 Joules, 2mS			
	UNIT INPUT	Fuse or circuit breaker for overload and short circuit protection			
	EM/RFI Filter	10 dB at 0.15 MHz, 50 dB at 30 MHz			
	Overload Protection	Automatic shutdown if overload exceeds 110% of nominal for 20 seconds or 125% for 2 seconds			
	Transfer	2/4 milliseconds, including detection time			
	Short Circuit	Output cut off immediately or input fuse/breaker protection			
BATTERIES	Type	Hot swappable, sealed, maintenance free gelled lead acid			
	Typical Recharge	4 hours to 90% capacity			
	Protection	Automatic self test and over discharge protection			
	Back-Up Time*	7-8 Min	13-14 Min		8.5-9.5 Min
	Nominal Battery Voltage	48 V	36 V	48 V	
	Charge Current	3.5 to 8A Adjustable			
	Optional External Battery Packs	4 pcs, 12v/7.2 AH	3 pcs, 12v/17 AH	4 pcs, 12v/17 AH	
	Supplied Battery Packs	Customer Configuration			
PHYSICAL	Net Weight Kg (lb)	22.5 (49.5)	46.0 (101)	50 (110)	57 (126)
	Dimensions in (mm) WxDxH	6.7x17.7x8.5 (170x450x215)	6.7x19.1x16.9 (170x485x430)		6.7x21.7x16.9 (170x550x430)

* **NOTE:** Battery backup times are approximate and will vary depending on factors such as ambient temperature, loads and battery age at the installation site.

4.6 Specifications (XL Models, Continued)

MODEL		1000XL	1500XL	2000XL	3000XL
ALARM	Battery Backup	Slow beeping sound (~0.25 Hz)			
	Battery Low	Rapid beeping sound (~1.00 Hz)			
	Overload	Continuous beeping sound			
INTERFACE	RS-232	Supports both RS-232 and dry contact signal. Provides power management functions and diagnostic functions including power status, battery low, schedule UPS ON/OFF, battery/load level display. Compatible with Windows 95/98/NT, Novell and Unix.			
CONFORMANCE	Safety	UL, cUL, TUV, CE, FCC (Pending)			
	Surge	Meets IEEE standard 587			
ENVIRONMENT	Ambient Operation	19600 Ft (6000 M) max elevation, 0-95% humidity non-condensing, 0-40 deg C			
	Audible Noise	<50 dBA at 1 meter from surface			
	Storage	49000 Ft (15000 M) max elevation			

NOTE: Specifications subject to change without notice.

4.6 Specifications (Rack Mount Models)

MODEL		800A-RM	1250A-RM	1500A-RM	2000A-RM
INPUT	Capacity	800VA	1250 VA	1500VA	2000VA
	Voltage	100V, 110V, 120V, 220V, 230V, 240V, +/- 25% at line input, single phase			
	Frequency	50 or 60 Hz +/- 5% (auto sensing)			
OUTPUT	Voltage (On Battery)	Pure sine wave output at nominal +/- 5%, -10% after low battery warning			
	Frequency (On Battery)	50 or 60 Hz +/- 0.5%			
	Voltage Regulation AVR	AVR automatically increases output voltage 15% above input voltage if line voltage is -9% to -25% of nominal. AVR automatically decreases output voltage by 15% if input voltage is +9% to +25% of nominal line voltage.			
PROTECTION AND FILTERING	SPIKE	320 Joules, 2ms			
	UNIT INPUT	Fuse or circuit breaker for overload and short circuit protection			
	EMI/RFI Filter	10 dB at 0.15 MHz, 50 dB at 30 MHz			
	Overload Protection	Automatic shutdown if overload exceeds 110% of nominal for 20 seconds, or 125% for 2 seconds			
	Transfer	2/4 milliseconds, including detection time			
	Short Circuit	UPS output cut off immediately or input fuse/breaker protection			
BATTERIES	Type	Hot swappable, Sealed, Maintenance free gelled lead acid			
	Typical Recharge	4 hours to 90% capacity			
	Protection	Automatic self-test and over discharge protection			
	Back-Up Time At Full Load (Min)*	8	4	5	
	Back-Up Time At Half Load (Min)*	22	13	16	
	Nominal Battery Voltage	24 V		36 V	48 V
	Charger Current	1.5A to 2.5A			
	Supplied Battery Packs	Built In			
PHYSICAL	Net Weight Kg(lbs)	18.0 (39.6)	23.5 (51.7)	26.1 (57.4)	28.4 (62.4)
	Dimensions WxDxH in (mm)	19x15x5 (483x381x130)			

NOTE: Specifications subject to change without notice.

4.6 Specifications (Rack Mount Models, Continued)

MODEL		800A-RM	1250A-RM	1500A-RM	2000A-RM
ALARM	Battery Backup	Slow beeping sound (~0.25 Hz)			
	Battery Low	Rapid beeping sound (~1.00 Hz)			
	Overload	Continuing beeping sound			
INTERFACE	RS-232	Supports both RS-232 and dry contact signal. Provides power management functions and diagnostic functions including power status, battery low, schedule UPS ON/OFF, battery/load level display. Compatible with Windows 95/98/NT, Novell and Unix			
ENVIRONMENT	Ambient Operation	11400 Ft (3500 M) maximum elevation, 0-95% humidity non-condensing, 0-40 deg C			
	Audible Noise	<40 dBA at 1 meter from surface	<45 dBA at 1 meter from surface		
	Storage	49000 Ft (15000 M) maximum elevation			
CONFORMANCE	Safety	UL, cUL, TUV, CE, FCC			
	Surge	Meets IEEE Standard 587			

NOTE: Specifications subject to change without notice.

*** NOTE:** Battery backup times are approximate and will vary depending on factors such as ambient temperature, loads and battery age at the installation site.

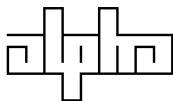

LIMITED 24-MONTH WARRANTY AC PRODUCTS

Alpha Technologies warrants its equipment to be free of manufacturing defects in material and workmanship for a period of 24 months from the date of manufacture. The liability of Alpha Technologies under this warranty is solely limited to repairing, replacing, or issuing credit for such equipment (at the discretion of Alpha Technologies), provided that:

1. Alpha Technologies' Customer Service Department is promptly notified, by facsimile or telephone, that a failure or defect has occurred.
2. Alpha Technologies' Customer Service Department issues a Return Materials Authorization (RMA) number, and designates the service location. The RMA must be clearly marked on the outside of the shipping container.
3. Purchaser is responsible for all in-bound shipping and handling charges (COD and freight collect will not be accepted without prior approval from Alpha Technologies); Alpha Technologies will pay out-bound surface shipping charges for return of repaired equipment.
4. A satisfactory examination of the returned unit by Alpha Technologies' Service personnel shall disclose that defects have not been caused by misuse, neglect, improper installation, repair, alteration, or accident, or failure to follow instructions furnished by Alpha Technologies. If Alpha Technologies' Service personnel determine that the unit has been damaged due to one of these causes, or if the unit is free of defects, a handling or repair fee may be assessed prior to returning the unit.

WITH RESPECT TO BATTERIES, PERIPHERAL DEVICES, ATTACHMENTS OR APPARATUS NOT MANUFACTURED BY ALPHA TECHNOLOGIES, ALPHA WILL ASSIGN TO THE PURCHASER ITS RIGHTS UNDER THE ORIGINAL MANUFACTURER'S WARRANTY OF SUCH BATTERIES, PERIPHERAL DEVICES, ATTACHMENTS OR APPARATUS, BUT OFFERS NO ADDITIONAL WARRANTIES IN CONNECTION THEREWITH.

THIS LIMITED 24-MONTH WARRANTY IS IN LIEU OF ALL OTHER WARRANTIES, EXPRESS OR IMPLIED, INCLUDING, BUT NOT LIMITED TO, IMPLIED WARRANTIES OF MERCHANTABILITY AND FITNESS FOR A PARTICULAR PURPOSE.

IN NO CASE SHALL ALPHA TECHNOLOGIES BE LIABLE FOR ANY INCIDENTAL, SPECIAL OR CONSEQUENTIAL DAMAGES WHATSOEVER, INCLUDING WITHOUT LIMITATION ANY CLAIM FOR LOST PROFITS OR REVENUES, EVEN IF ALPHA TECHNOLOGIES HAS BEEN ADVISED OF THE POSSIBILITY OF SUCH, FOR BREACH OF THIS OR ANY OTHER WARRANTY, EXPRESS OR IMPLIED.

Any action for breach of this limited 24-month warranty must be brought within a period of 24 months from date of manufacture.

This limited 24-month warranty does not extend to any unit that has been repaired or altered by any party other than Alpha Technologies or its Authorized Service Center.

Alpha Technologies reserves the right to discontinue particular models and to make modifications in design and/or function at any time, without notice and without incurring obligations to modify previously purchased units.

8/96

To order parts, contact Alpha Technologies
Customer Service department directly at:

- **United States:** (360) 647-2360
- **Canada:** (604) 430-1476
- **United Kingdom:** +44-1279-422110
- **Germany:** +49-9122-79889-0
- **Middle East:** 357-5-375675
- **Australia:** 612-9894-7866

**For emergency support, 7 days a week,
24 hours a day, call:**

USA: 1-800-322-5742

CANADA: 1-800-667-8743

IMPORTANT

Emergency shutdown procedure
on the inside back cover.

EMERGENCY SHUTDOWN PROCEDURE

1 Press the OFF switch

2 Unplug the line cord from the wall receptacle.

If the power is hard wired, turn off the utility circuit breaker.

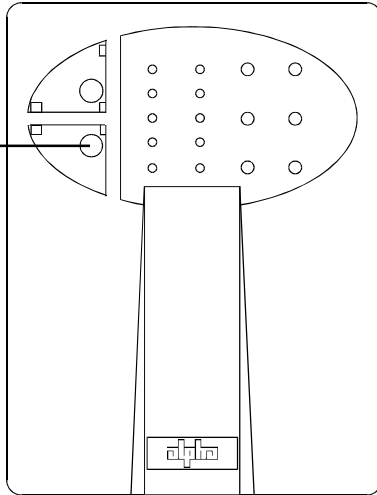

The ALI-PLUS contains more than one live circuit. In an emergency, line power may be disconnected at the service entrance, main electrical panel or at the input, but there can be AC power at the outputs.

▶ **USA, LATIN AMERICA
& ASIA PACIFIC**

Alpha Technologies
3767 Alpha Way
Bellingham, WA 98226
Tel: (360) 647-2360
Fax: (360) 671-4936

▶ **CANADA**

Alpha Technologies
4084 McConnell Court
Burnaby, BC, V5A 3N7
Tel: (604) 430-1476
Fax: (604) 430-8908

▶ **UNITED KINGDOM,
EUROPE AND AFRICA**

Alpha Technologies
Cartel Business Estate
Edinburgh Way
Harlow, Essex CM20 2DU
Tel: +44-1279-422110
Fax: +44-1279-423355

▶ **GERMANY**

Alpha Technologies
Hansastrasse 8
D-91126 Schwabach
Tel: +49-9122-79889-0
Fax: +49-9122-997321

▶ **MIDDLE EAST**

Alphatec
P.O. Box 6468
3307 Limassol, Cyprus
Tel: +357-5-375675
Fax: +357-5-359595

▶ **AUSTRALIA**

Alpha Technologies
8 Anella Ave., Unit 6
Castle Hill, NSW 2154
Tel: +61(0)2 9894-7866
Fax: +61(0)2 9894-0234

Power]

<http://www.alpha-us.com>

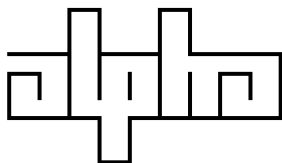

Alpha sales and service offices located throughout the world

Printed in Canada

017-165-B0-001 05 / 01

© 2001 Alpha Technologies